

#DT16

Deb Tucker's
Studio 180
Design
 Presents

Corner Pop™

A Tool to give you Perfectly Filled Corners with Less Waste

Can be used with Patterns Calling for Traditional Folded Corners
 High Precision for 22 Different Sizes
 Right & Left Handed Instructions

© 2014
 Studio 180 Design Ltd.

Finally a tool and technique that will give you high success with adding fabric corners to basic shapes!

For years we've been layering small squares on big squares, marking & stitching on a diagonal line, then hoping everything lines up when we fold the small corner section back into place. Well if you've tried it, you know the pitfalls: too big, too short, too crooked and way too wasteful! Well, no more! With your new **Corner Pop™** tool, you will be able to trim rather than mark, add an oversized replacement triangle and then square everything to a perfect size. Like all the Studio 180 Design tools, this allows every level quilter an opportunity for increased success without undue stress.

With your new **Corner Pop™** tool, you can choose from any of the 22 size options available and accurately remove a 90° corner from a base (primary) shape such as square, rectangle, pieced unit, or block and leave the necessary ¼" seam allowance intact. You'll then add an oversized replacement half square triangle and use ruler guidelines and cutting edges to quickly clean up the corners to the perfect shape and size. Each corner will be completely filled and have all seams properly located for better piecework. In addition to the increased accuracy, you'll also be saving fabric and have seam pressing options not available with the traditional "folded corner" techniques. Truly a new day for the quilting community! Just use the easy directions that follow and soon you'll be "Popping" corners off of all types of shapes and adding increased pizzazz to all of your quilting projects.

Step 1 - Cut or trim your base shape to the exact size required for your project. This base shape can be a simple square, rectangle, or any pieced unit (half square triangle unit, hourglass unit, V block unit, etc). This base could also be completed full size blocks or setting triangles for "on point" block arrangements.

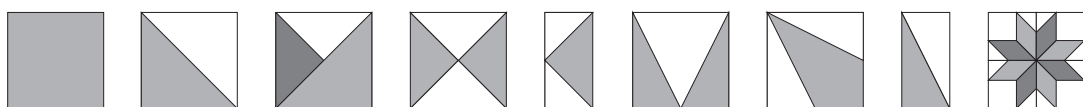

Step 2 - Choose the size you wish to cut away from a corner. If designing your own projects, you can use any increment you desire. The ruler lines and numbers are the finished size of the replacement triangle. If working with a published pattern that uses “folded corners,” consult the cutting chart below before starting your project. This guide will give you the correct lines to use for the corner “Cut Away” as well as the correct size to cut for the replacement triangles. We’ll use a 2” Cut Away corner in our illustrations.

Published Size for Folded Corner	1¼”	1½”	1¾”	2”	2¼”	2½”	2¾”	3”	3¼”	3½”	3¾”	4”	4¼”	4½”	4¾”	5”	5¼”	5½”	5¾”	6”	6¼”	6½”
Finished Size / Cut Away Size on Corner Pop™ Tool	¾”	1”	1¼”	1½”	1¾”	2”	2¼”	2½”	2¾”	3”	3¼”	3½”	3¾”	4”	4¼”	4½”	4¾”	5”	5¼”	5½”	5¾”	6”
Replacement Triangle Square Size*	2”	2¼”	2½”	2¾”	3”	3¼”	3½”	3¾”	4”	4¼”	4½”	4¾”	5”	5¼”	5½”	5¾”	6”	6¼”	6½”	6¾”	7”	7¼”
Corner Trim Down Line	¾”	1”	1¼”	1½”	1¾”	2”	2¼”	2½”	2¾”	3”	3¼”	3½”	3¾”	4”	4¼”	4½”	4¾”	5”	5¼”	5½”	5¾”	6”

*Remember you’ll get 2 triangles from each square

Step 3 - Find the correct line on the Corner Pop tool. Examine your tool and locate the two areas designated as “Cut Away Corners.” One of these sections is for whole inch and half inch increments and the other is for quarter inch and three quarter inch increments. In our example you’ll be looking for the line labeled with the number 2.

Step 4 - Cut away a corner from your base shape. Place the ruler lines over the corner you wish to cut away as shown in the diagrams. Right handers should place the fabric corner and tool in the lower left for cutting. Left handers should place the fabric corner and tool in the lower right for cutting. Use care here to align the lines on the tool with the raw edges of the base unit. The triangle you trimmed off is excess and can be discarded or used for future scrap projects. The base unit now has the proper ¼” seam allowance for adding the correctly sized replacement corner.

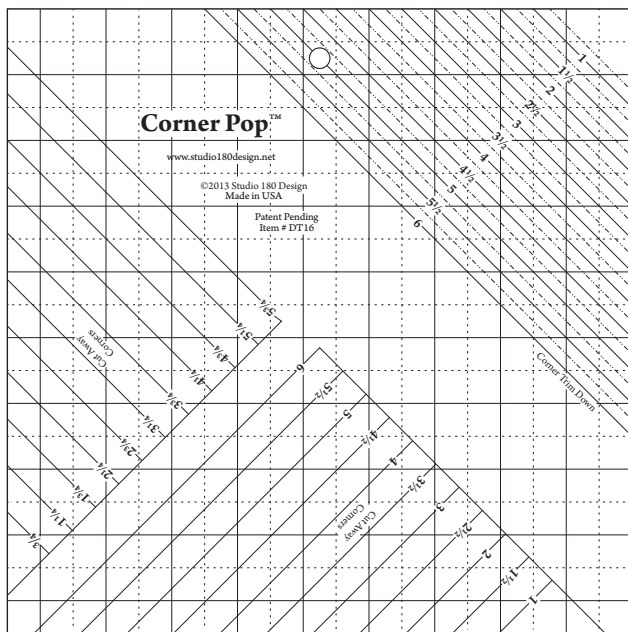

Step 3 -
Find Desired Finished Size

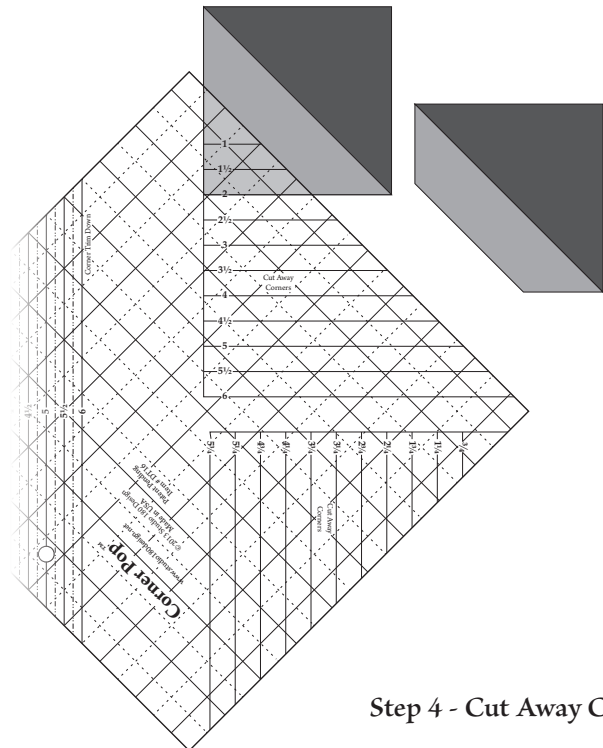

Step 4 - Cut Away Corner

Step 5 - Cut Replacement Triangles. To make a triangle that is slightly larger than the space you need to fill, cut squares that are 1¼” larger than the size you chose to cut away from your base shape. Cut this square in half diagonally into two slightly oversized replacement triangles to fill the empty corner. For our example you would cut the replacement triangle squares 3¼” (2” + 1¼”). Consult the chart above for the suggested sizes.

Step 6 - Position and stitch replacement triangle onto base. Center the replacement triangle right sides together with the base shape. Align the long diagonal edge of the replacement triangle with the newly trimmed edge of the base. To stitch, place the base shape on top for the most accurate 1/4" seam. You may need to make minor adjustments to your 1/4" seam depending on the weight of your fabrics and the weight of your thread. Consider making several practice pieces before "power sewing" your entire project.

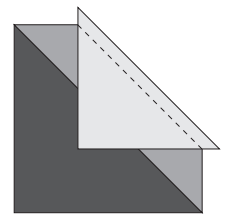

Step 6 - Position & Stitch

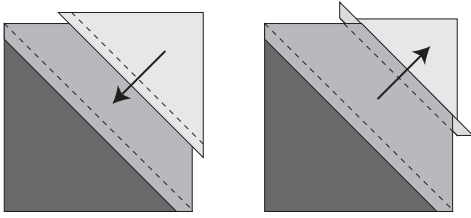

Step 7 - Press. One of the biggest bonuses of using this construction technique is the fact that you can actually choose which way to press the sewn seam - toward the base, toward the replacement triangle or open. Having this option will help eliminate bulky intersections that were always an issue with the Folded Corner process.

Step 7 - Press in Desired Direction

Step 8 - Trim. You now have a corner in place that is slightly larger than the base shape and ready to be trimmed. Locate the Corner Trim Down section of the **Corner Pop™** tool and find the diagonal line that corresponds to your Cut Away size. For example if you cut away using the 2" line you will use the 2" diagonal on the trim down side. Place the correct diagonal on your diagonally sewn seam and line up the cutting edges of the ruler with the raw edges of the base shape. See the diagrams below for right and left hand placement. In addition to the diagonal guidelines, there are half inch and full inch grid lines on the ruler to help align the tool with the fabric shape. Trim away the excess replacement triangle fabric to produce a shape that is properly sized with seams properly positioned.

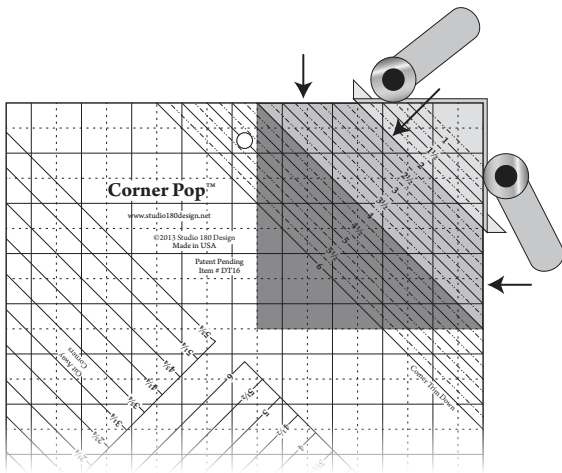

Step 8 - Right Handed Trimming

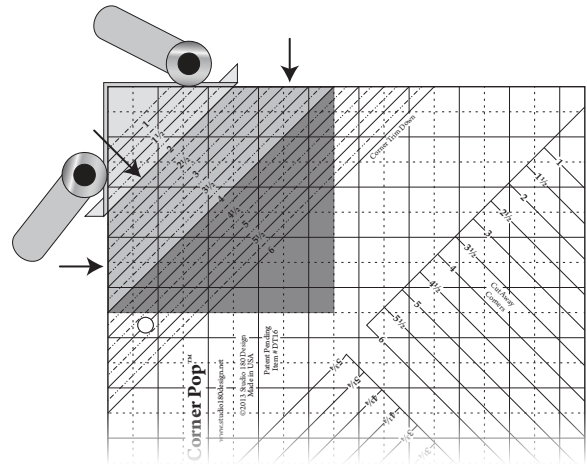

Step 8 - Left Handed Trimming

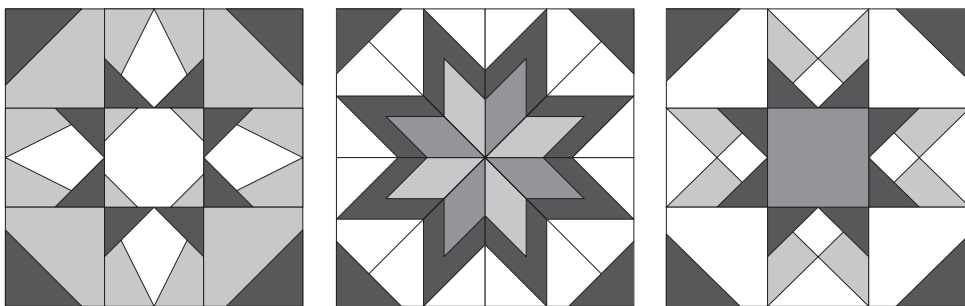

Team up your **Corner Pop™** with other tools designed by **Studio 180 Design**. Purchase them at your local quilt shop or from our web store, **Studio180Design.net**. While you are there, check out our free online video demonstrations.