

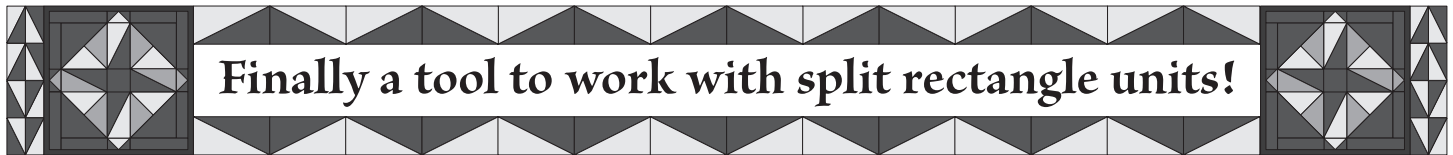

8 Different Sizes ◊ Right and Left Handed Instructions ◊ Free Online Video Demonstrations



Cutting the Strips

Step 1 - Determine the desired finished size of the rectangular units you wish to make.

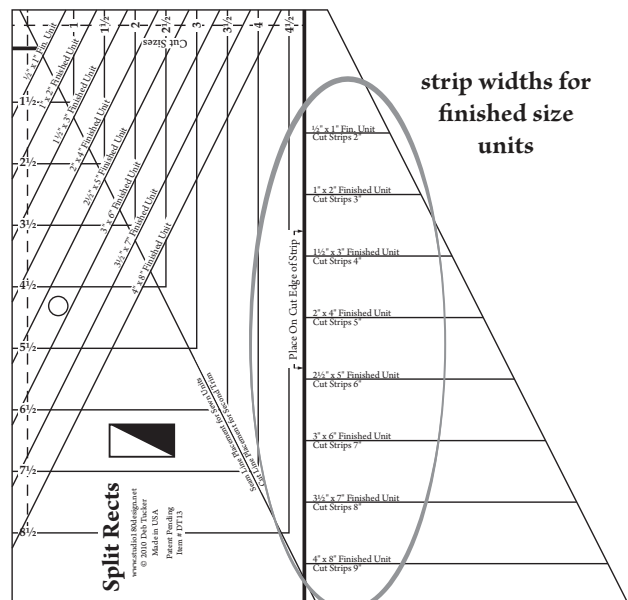

Step 2 - Locate the area on the ruler that lists the finished size units and the cutting size for the strips near the slanted side of the tool.

Step 3 - Cut all strips the listed size. Refer to cutting chart for the approximate number of elongated triangles that can be cut from standard fabric width strips.

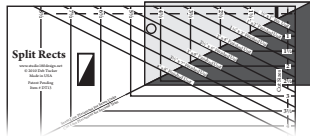

Cutting the Rectangles

Step 4 - Take note of the desired slant of the seam for the units you wish to make. Some rectangles will have seams that slant from lower right to upper left when they are placed vertically and some rectangles will have seams that slant from lower left to upper right. It is important to determine whether you want to make just one type of Split Rects unit for your particular project or whether you will need both types of Split Rects units (mirror image units). Refer to the chart below for more information.

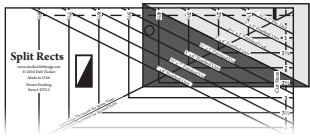
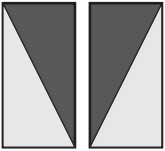
Desired Unit Seam Slant (units shown right side up)	Strip Placement for Right Hand cutting	Strip Placement for Left Hand cutting	Guideline Placement for Trimdown
Unit Type #1 - lower right to upper left 	<u>All strips right sides up</u> on cutting mat Placed horizontally Cut from left to right	<u>All strips right sides up</u> on cutting mat Placed vertically Cut from bottom to top	 Align with Common Diagonal
Unit Type #2 - lower left to upper right 	<u>All strips wrong sides up</u> on cutting mat Placed horizontally Cut from left to right	<u>All strips wrong sides up</u> on cutting mat Placed vertically Cut from bottom to top	 Align with Sizing Diagonal
Unit Types #1 & #2 - mirror image units 	Strips facing <u>right sides together or wrong sides together</u> on cutting mat Placed horizontally Cut from left to right	Strips facing <u>right sides together or wrong sides together</u> on cutting mat Placed vertically Cut from bottom to top	See Above Diagrams

Finished (Sewn) Size of Unit	Cut Size of Unit (Trim Size)	Side triangle strip	Elongated triangles per strip
½" x 1"	1" x 1½"	2"	22
1" x 2"	1½" x 2½"	3"	17-18
1½" x 3"	2" x 3½"	4"	14
2" x 4"	2½" x 4½"	5"	12
2½" x 5"	3" x 5½"	6"	10
3" x 6"	3½" x 6½"	7"	8
3½" x 7"	4" x 7½"	8"	6
4" x 8"	4½" x 8½"	9"	4

Step 5 - Place strips on mat according to the chart above for your desired type of units - right sides up, wrong sides up or facing.

Step 6 - **Right handers** place strips horizontally on the cutting mat. **Left handers** place strips vertically on the cutting mat.

Step 7 - **Position** ruler on the strip with the broad black line against the trimmed end of the strips and the desired finished size guide line along the raw edge of the strips.

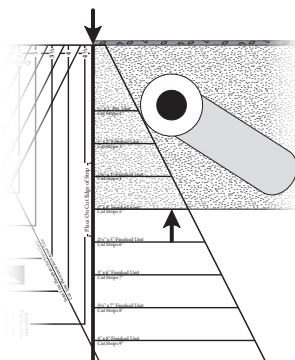

**Step 5 to 7 -
Right Handers**

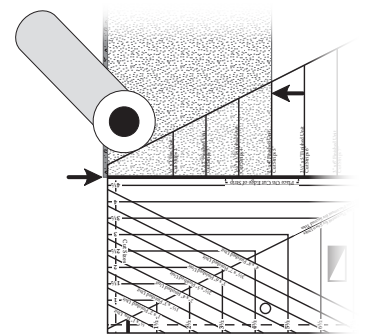

**Step 5 to 7 -
Left Handers**

Step 8 - Trim along the slanted edge of the ruler to yield elongated triangles that will create rectangles when stitched along their long diagonal edges.

Step 9 - Rotate the ruler one half turn as shown in the illustration and align the small second trim “nub” line on the long edge of the strip and the “Second Trim” guide line along the just-trimmed edge of the strip.

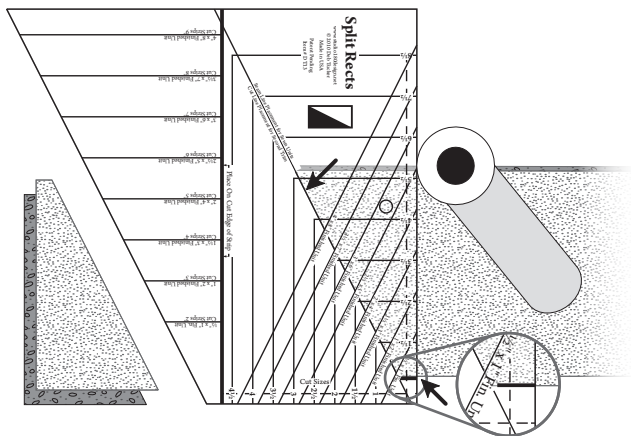

Step 9 - Right Handers

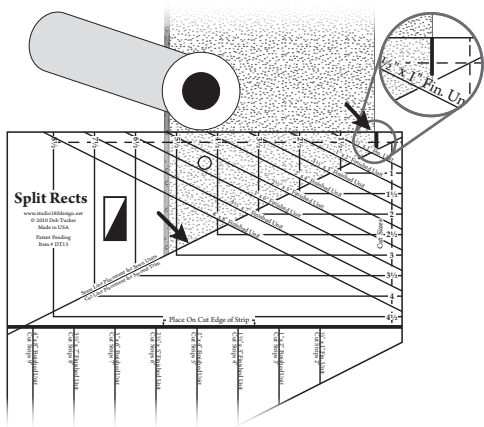

Step 9 - Left Handers

Step 10 - Trim along the straight edge of the ruler to create the next pair of elongated triangles.

Step 11 - Continue to rotate the ruler to make one trim along the slanted edge and then one trim along the opposite straight edge to make your required number of pieces.

Stitch, Press and Trim

Step 12 - Stitch the elongated triangles by placing them right sides together with the long, bias edge of the pieces aligned. Because they are oversized, there is no need for a lot of fuss at this time. I tend to center the two pieces with just a bit of overlap at the ends, but close is good enough.

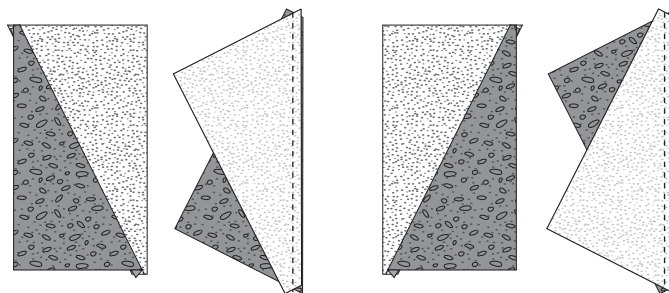

Unit Type #1

Unit Type #2

Step 12 - Stitch

Step 13 - Press the seams either toward the darker fabric or open. I will press open if I have more than 6 or 8 seams coming together at one point to help eliminate bulky seams.

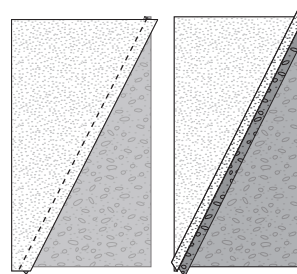

Step 13 - Press

Note: The units are designed to be oversized when sewn and then trimmed to a precise measurement after the sewing and pressing are complete. As long as you are pretty close with your positioning and stitching, you should have enough fabric on all four sides for a clean-up trim. A much less stressful method than ever before.

Step 14 - Position sewn units on a cutting mat. For right hand cutting place units horizontally, for left hand cutting place units vertically.

Step 15 - Align either the “Common Diagonal” or the correct “Size Diagonal” with the seam you have sewn (see chart). These will vary depending on the slant of the seam in your unit.

Step 16 - Check to make sure that the fabric unit is completely contained within the trim down lines for the desired size of Split Rects™ unit. Remember that a 2” x 4” “Finished Size” unit will have a “Cut Size” of 2½” x 4½”.

Step 17 - Trim along both edges.

Step 18 - Rotate the fabric unit and reposition the ruler on top. Align correct “Cut Size” measurement with the trimmed corner and the same diagonal line used in the first trim.

Step 19 - Trim the remaining two edges of the Split Rects™ unit.

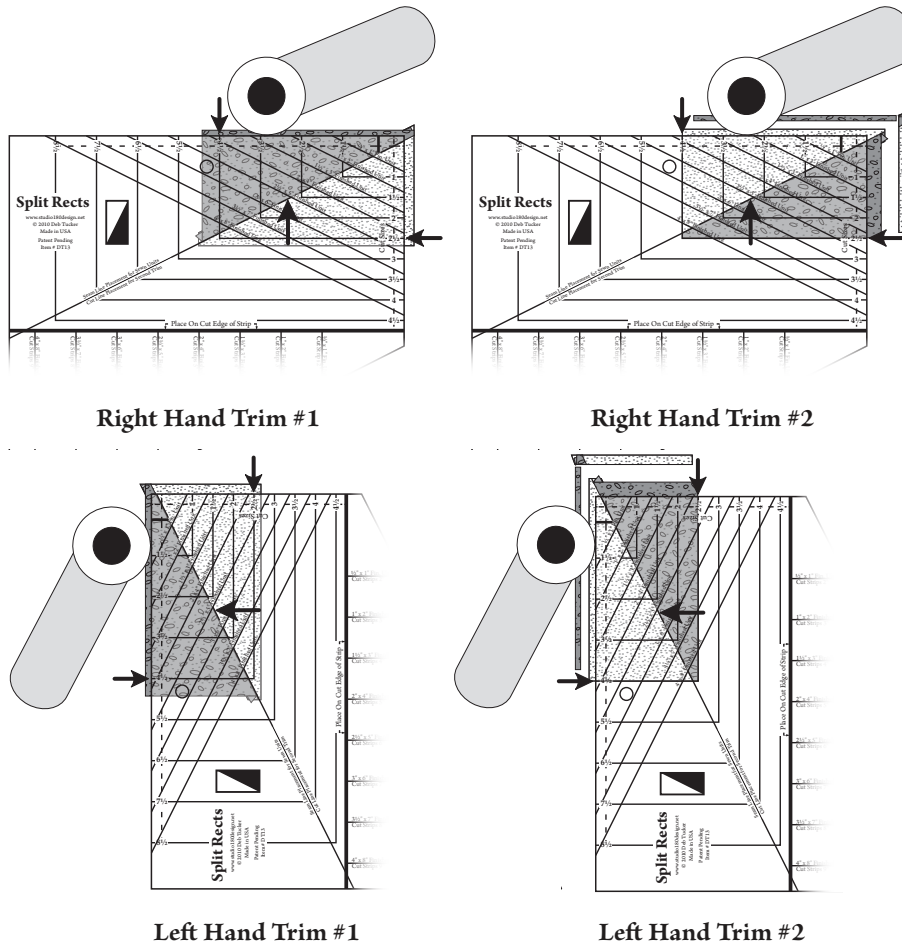

Steps 14 to 19 - Trim

Congratulations!

You will now have perfectly sized units with the seams positioned exactly right to give you crisp points every time. You will find that having the units trimmed precisely makes your quilt construction a much simpler and less stressful operation.

Enjoy your new Split Rects™ tool and be sure to check out our other Fundamental Tools for making basic units as well as our Rapid Fire® line of tools and techniques. Find them at your local quilt shop or by visiting our website

www.Studio180Design.net

and don't forget to watch our free online video demonstrations whenever you need an initial introduction or review.